

20-BIN SORTER STAPLER
(Machine Code: A658)

1. SPECIFICATIONS

Paper Size for Bins:	Sort/Stack Modes: Maximum: A3, 11 x 17" Minimum: B5, 8 1/2 x 11"
Paper Weight for Bins:	Sorting: 52 ~ 157 g/m ² (14 ~ 42 lb) Stacking: 52 ~ 157 g/m ² (14 ~ 42 lb) Stapling: 52 ~ 157 g/m ² (14 ~ 42 lb)
Bin Capacity:	Sorting: A4, 8 1/2 x 11" or smaller: 30 copies B4, 8 1/2 x 14" or larger: 25 copies Stacking: A4, 8 1/2 x 11" or smaller: 25 copies B4, 8 1/2 x 14" or larger: 20 copies
Stapler Capacity:	2 ~ 20 copies
Proof Tray Capacity:	100 sheets (80g/m ² , 20 lb)
Number of Bins:	20 bins + proof tray
Stapling Position:	a = 6 ± 3 mm b = 6 ± 3 mm

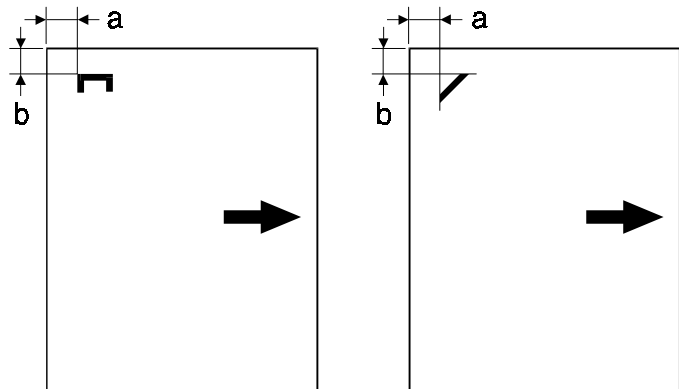

A658V500.wmf

Staple Replenishment:	Cartridge exchange (2,000 staples/cartridge)
Power Source:	DC 24 V (from the copier)
Power Consumption:	Average: less than 35 W Average for Sorting: less than 30 W Average for Stapling: less than 33 W
Weight:	20.5 kg (27.4 lb)
Dimensions (W x D x H):	430 x 570 x 680 mm (15.0" x 21.6" x 17.5")

- Specifications are subject to change without notice.

2. COMPONENT LAYOUT

2.1 MECHANICAL COMPONENT LAYOUT

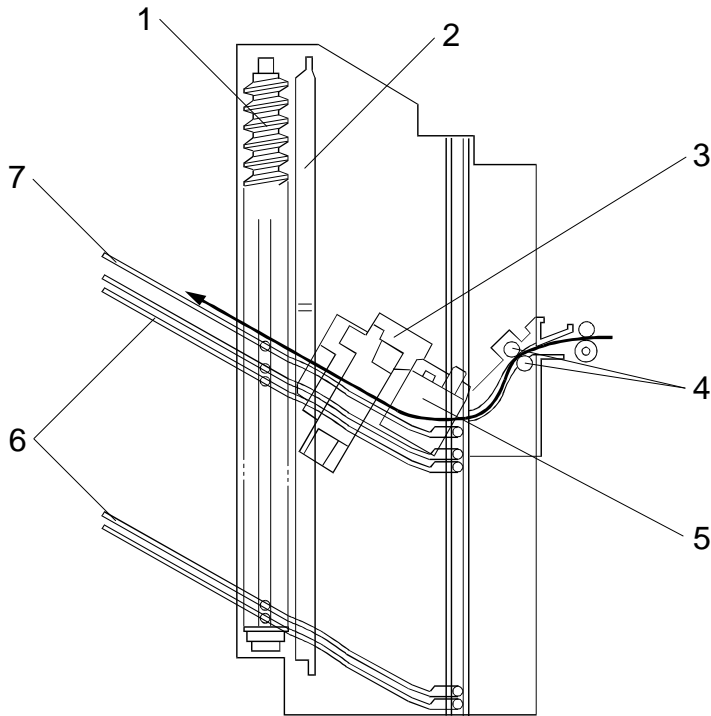

A658V501.wmf

1. Helical Wheels
2. Jogger Plate
3. Grip Assembly
4. Transport Rollers
5. Staple Unit
6. Bins
7. Proof Tray

2.2 DRIVE LAYOUT

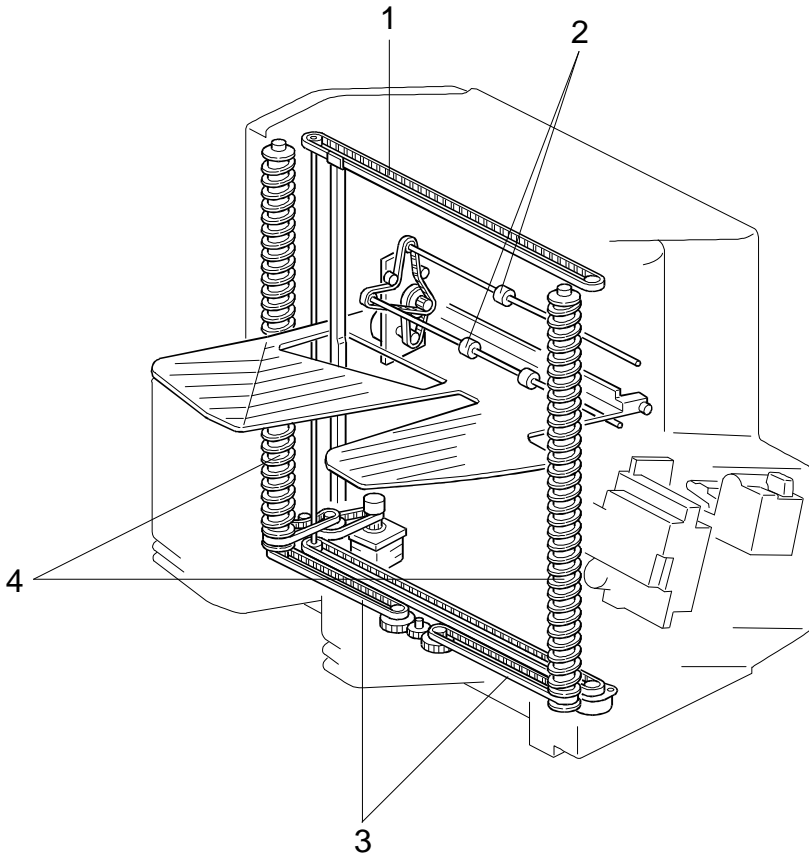

A658V502.wmf

- 1. Jogger Drive Belt
- 2. Transport Roller
- 3. Wheel Drive Belts
- 4. Helical Wheels

2.3 ELECTRICAL COMPONENT DESCRIPTION

Refer to the electrical component layout on the reverse side of the Point to Point Diagram (on waterproof paper).

Symbol	Name	Function	Index No.
Motors			
M1	Main Drive	Drives the transport roller	16
M2	Jogger	Drives the jogger plate to square the copies	9
M3	Bin Drive	Drives the bins	14
M4	Stapler	Drives the stapler hammer	7
M5	Grip	Drives the grippers forwards and back into the bin to grip the copies and bring them to the stapling position	3
Sensors			
S1	Bin (Phototransistor)	Detects whether there is any paper in the bins (light receiving element)	1
S2	Grip Home Position	Detects when the grip assembly cam gear has rotated once	6
S3	Bin Home Position	Detects whether the bins are at home position	11
S4	Sorter Entrance	Detects paper jams	2
S5	Jogger Home Position	Detects whether the jogger plate is in its home position	13
S6	Wheel	Detects the bin position.	12
S7	Bin (LED)	Detects whether there is paper in the bins (light emitting element)	10
S8	Stapler Paper	Detects whether any copies are under the hammer.	4
S9	Staple End	Detects when the staples run out	18
S10	Staple Hammer Home Position	Detects whether the stapler hammer is at home position	17
Switches			
SW1	Door Safety	Cuts the dc +24 V supply when either the unit or the stapler cover is opened.	5
SW2	Stapler	Cuts the signals to the stapler.	8
Circuit Board			
PCB1	Main	Controls all sorter/stapler functions	15

3. BASIC OPERATION

3.1 NORMAL MODE AND SORT/STACK MODE

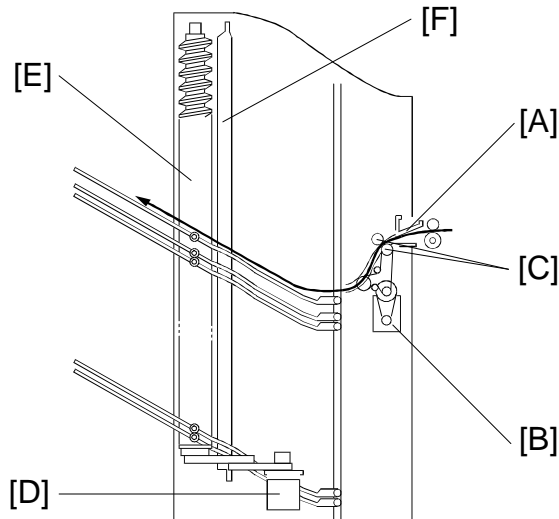

A658D500.wmf

Copies exiting the copier pass through the entrance guide plate [A]. The transport roller will send copies either to the proof tray or to each bin, depending on the selected mode.

During copying, all rollers in the sorter stapler transport the paper at a speed which depends on the copier. When the trailing edge of the copy passes the fusing exit sensor, the speed of the rollers changes to 600 mm/s. This makes enough time for the jogger plate to square the stack of paper and to stack the paper smoothly into the bins.

– Normal (proof) mode –

When the  key is pressed, the transport motor [B] energizes to rotate the transport rollers [C]. The transport rollers send copies to the proof tray directly.

– Sort mode –

When sort mode is selected, the bin drive motor [D] energizes to rotate the helical wheels. The helical wheels [E] rotate twice to move the top bin to the transport roller position, then the first copy is delivered to the top bin.

After the first copy of the first original has been fed to the top bin, the bin drive motor moves the bins up one step (the helical wheels rotate once) so that the second copy of the first original will be delivered to the next bin.

The jogger plate [F] squares the copies after each copy has been fed to a bin. After the copies of the first original have been delivered to each bin, the sorter stapler maintains its status (the bin drive motor does not rotate).

The first copy of the second original is delivered to the final bin that was used for the first original, then the final bin descends one step. The bins descend each time a copy of the second original is delivered.

The direction of motion of the bins alternates for each page of the original until the copy run is finished.

– **Stack mode** –

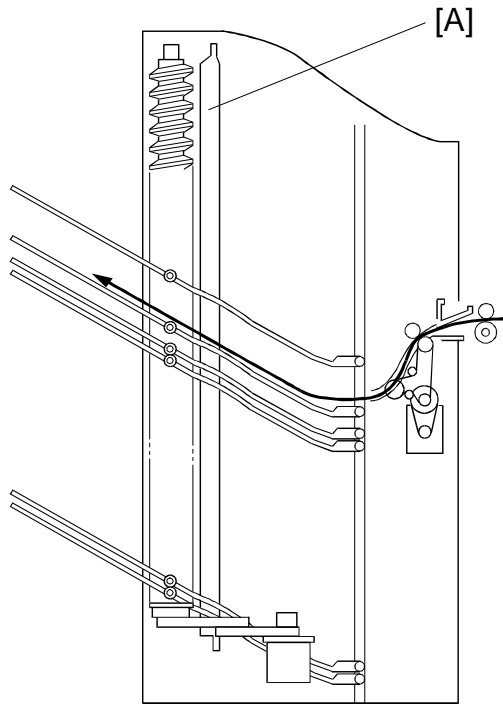

A658D501.wmf

When stack mode is selected, the top bin advances to the transport roller position in the same way as in sort mode.

After the first copy is delivered to the top bin, the jogger plate [A] moves across to square the copy. The jogger plate squares the copies after each copy has been fed to a bin.

After one set of copies for the first original has been delivered to the top bin, the bin drive motor moves the bins up one step. Then, one set of copies of the second original will be delivered to the next bin.

3.2 STAPLE MODE

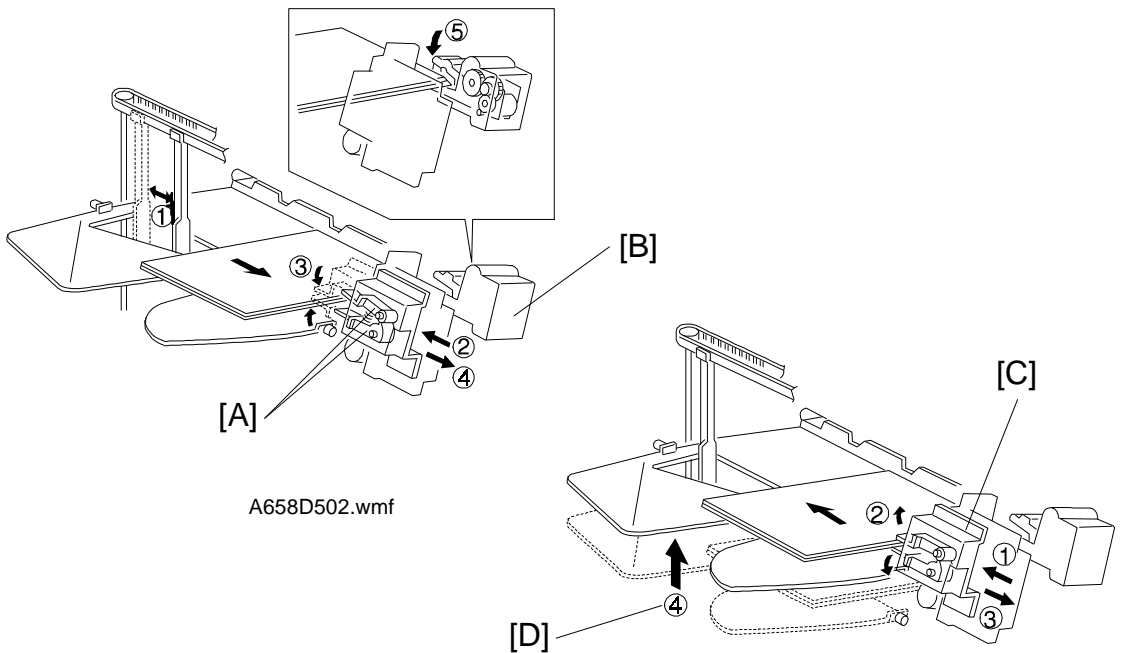

The stapler is only available in sort mode.

When the jogger plate has squared the final set of copies, the grip arms [A] move inside the front side frame and catch the paper. The grip assembly brings the copies into the stapler [B], and the stapler staples the copies.

After stapling, the grip assembly [C] brings the stapled copies back to the bin and releases the copies. Then the grip assembly goes back to the normal position. The bin either advances or descends one step [D] (depending on whether the page is an odd or even numbered page of the original).

When the final set of copies has been stapled, the bins go back to the standby position.

There are two staple modes.

– Automatic Stapling –

In ADF mode, when staple mode is selected before pressing the  key, copies will be delivered to each bin and stapled automatically.

– Manual Stapling –

In platen cover mode, after the copies have been sorted into the bins, the staple mode LED starts to blink. If the sort key is pressed while this LED is blinking, the copies will be stapled.

3.3 BIN DRIVE MECHANISM

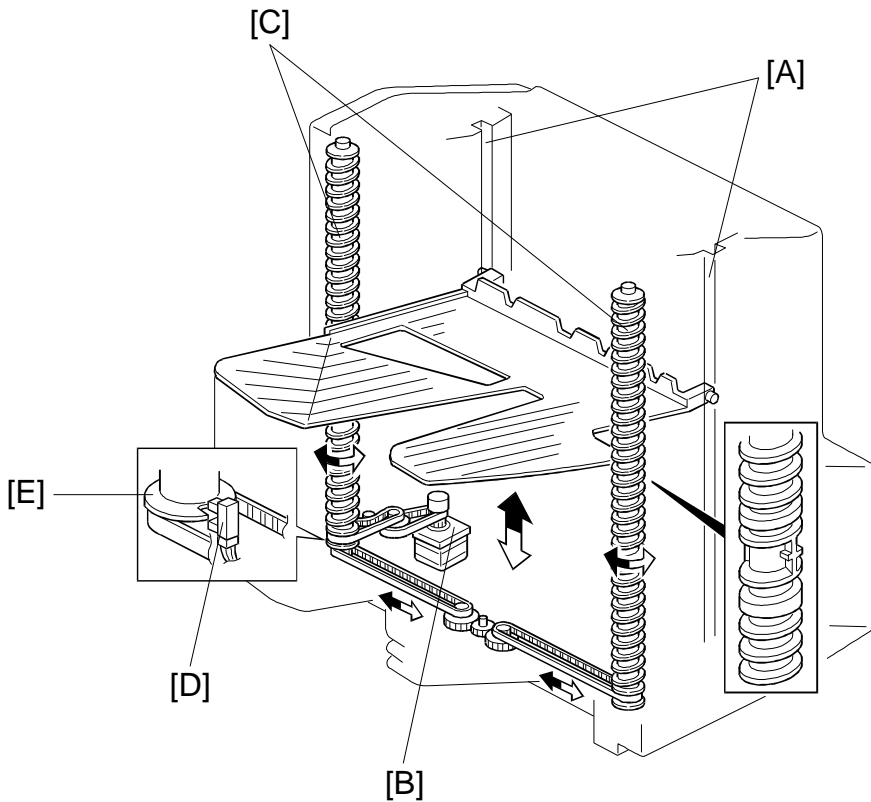

A658D504.wmf

The bin drive mechanism moves the bins up and down to receive copies.

There are four pins on each bin. Two pins fit into the slots [A] in both the front and rear side frames; the pins slide up and down in these slots. The other two pins fit into the slot in the helical wheels; as the helical wheels turn, these pins move up and down, and the other pins move up and down in the slots at the other end of the bin.

The bin drive motor [B] drives the helical wheels [C] through timing belts as shown. When the motor rotates clockwise, the bins lift; when it rotates counterclockwise, the bins lower. There is a wheel sensor [D] located under the actuator [E] on the rear helical wheel; the actuator has a slot which detects when the helical wheel has rotated once.

When the bins are advanced, the helical wheels rotate once for each step. As the pitch of the spiral on the helical wheel is greater when the bins are at the stapling and paper exit area than when the bins are elsewhere, the amount of bin shift is greater when the bins are at the stapling and paper exit area. This leaves enough space to staple and stack the copies. Also, this reduces the total machine height.

3.4 BIN HOME POSITION

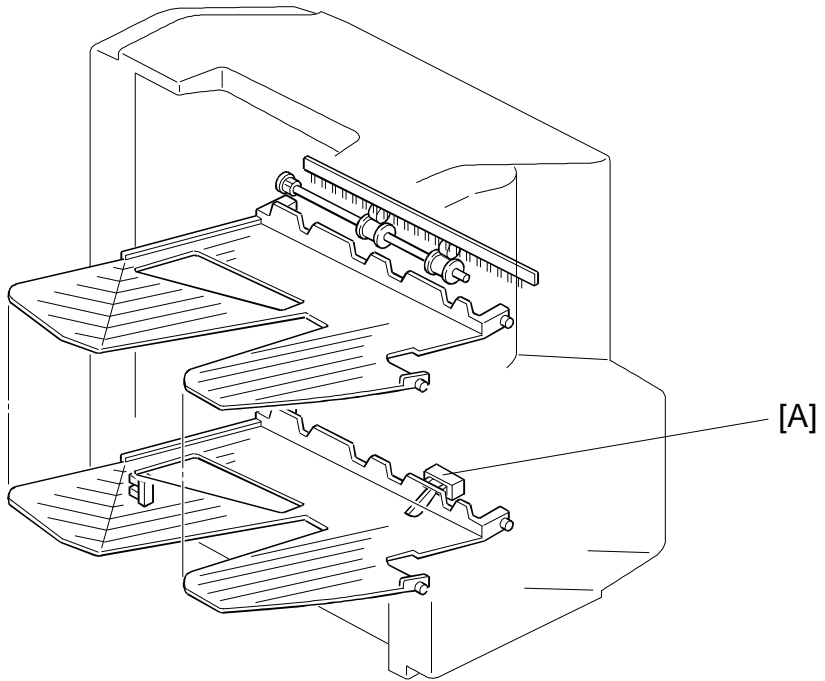

A658D505.wmf

The bin home position sensor [A] ensures that the proof tray is lower than the transport roller when the bins are in the home position.

When the main switch is turned on, the sorter stapler initializes itself to check whether the component parts work or not. At this time, the bin drive motor raises the bins for a few moments, then it lowers the bins until the bottom bin actuates the bin home position sensor.

3.5 JOGGER MECHANISM

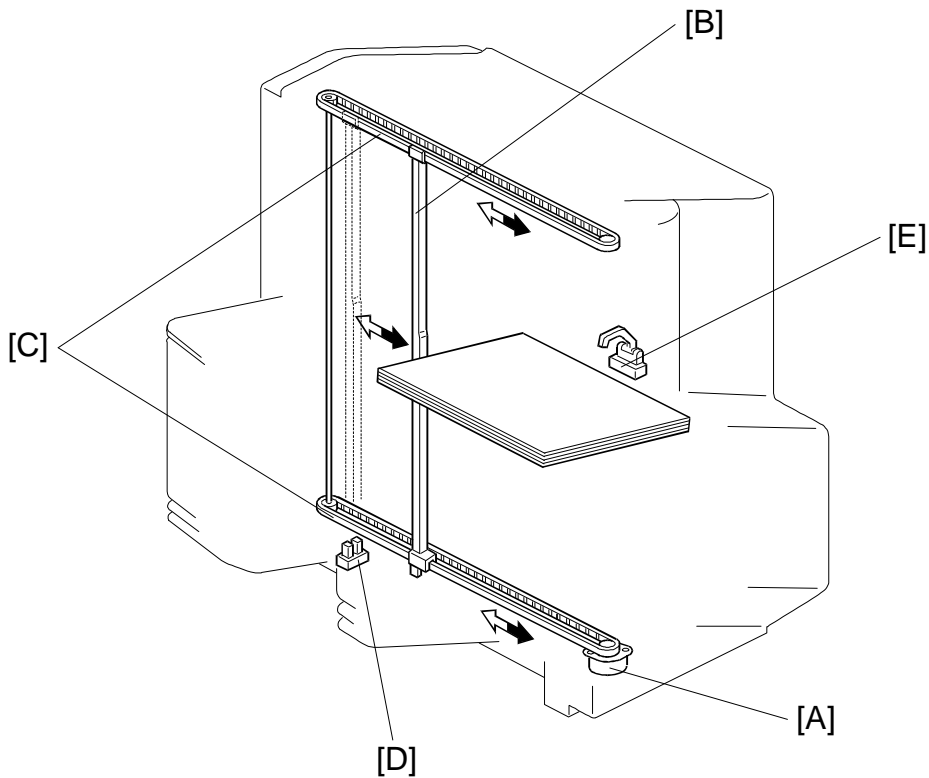

A658D506.wmf

The jogger motor [A] drives the jogger plate [B] through the timing belts [C].

The jogger is at home position when the actuator on the jogger plate goes into the jogger home position sensor [D].

At standby, the jogger plate is at the home position. When the  key is pressed, the copier sends the paper size information to the sorter stapler.

In sort, staple, and stack modes, the jogger moves three times to square the stack of paper. First, when the paper has been fed completely into the bin (at the proper time after the copy has passed through the entrance sensor [E], depending on the paper length), the jogger motor moves the jogger plate out of the jogger home position. Then, the jogger motor drives the jogger plate to the width of the copy. Finally, the jogger plate moves inward to push all the copies against the front side frame, which squares the sheets of paper. Then the jogger plate returns to the home position.

3.6 GRIP ASSEMBLY

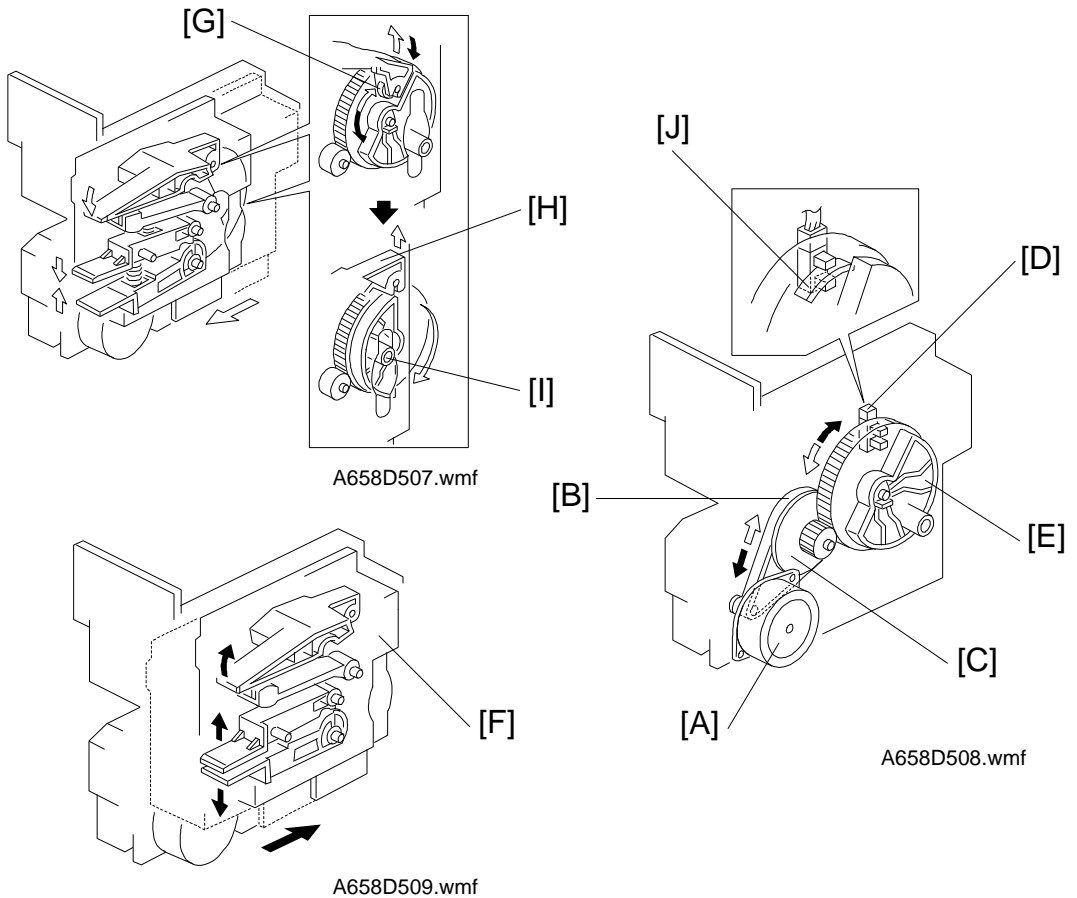

The grip assembly consists of the grip motor [A], the timing belt [B], the drive gear [C], the grip home position sensor [D], and the cam gear [E].

The grip motor drives the cam gear through the timing belt and drive gear. Cam gear rotation drives the mechanism that catches the copies and moves the grip arm unit [F]. When the cam gear rotates clockwise one full turn, the grip arm moves to catch the copies and returns to the home position to prepare for stapling. After stapling, the cam gear rotates counterclockwise once so that the stapled copies go back to the bin, and the cam gear returns to its home position.

When the cam pushes the roller [G] on the lever [H] and the lever pushes the grip arm, the grip arm can catch the copies.

A pin [I] on the cam gear fits into the slot in the grip arm unit. So, when the cam gear rotates, the slot moves the grip arm unit inward and outward.

The actuator [J] on the cam gear activates the grip home position sensor once every rotation of the cam gear. This allows the sorter stapler to determine that the cam gear has rotated once.

3.7 STAPLER UNIT

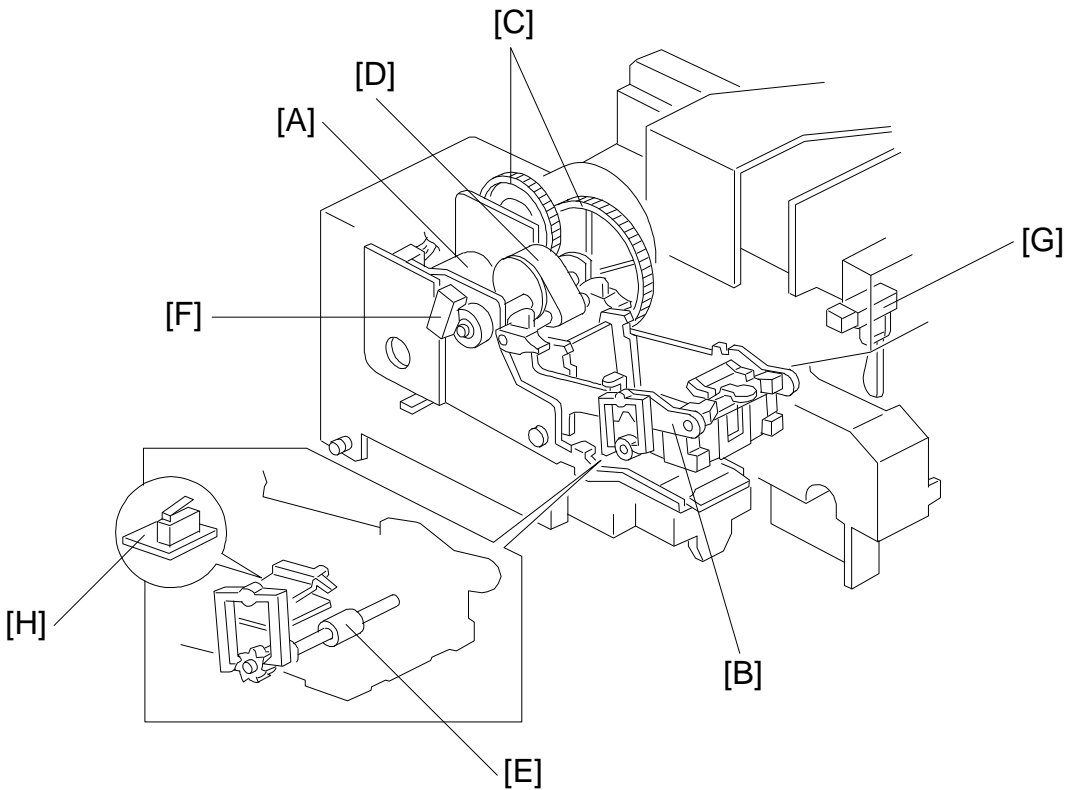

A658D510.wmf

The stapler motor [A] drives the staple hammer [B] using the gears [C] and the eccentric cam [D].

The roller [E] feeds the staple sheets under the hammer.

When the aligned copies are brought to the staple position by the grip unit, the stapler motor starts rotating and the copies are stapled. When the cam completes one rotation, the staple hammer home position sensor [F] is deactuated and the stapler motor stops.

When the stapler paper sensor [G] in the grip assembly does not detect any copies under the hammer, the stapler motor does not rotate.

When the trailing edge of the last staple sheet pass through the staple end sensor [H], the sorter stapler enters the staple near end condition. After the current job is completed, the Add Staples indicator lights on the operation panel. Then the copier cannot be used whenever the staple mode is selected.

3.8 STAPLER SWITCH

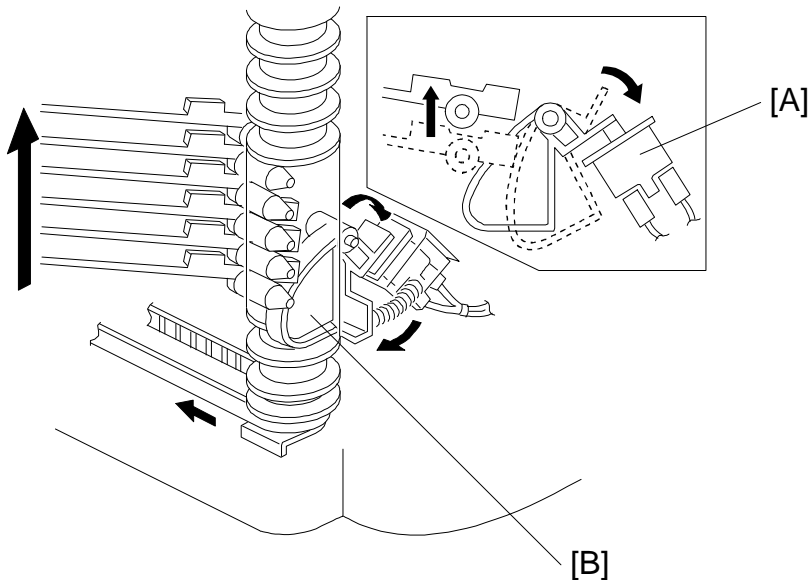

A658D511.wmf

The stapler switch [A] below the grip assembly cuts the dc +24 V supply to the stapler. In proof mode, all bins lower and push the lever [B]. This opens the stapler switch so that the signal to the stapler is cut. In sort and staple modes, all bins are advanced and the switch is closed so that the signal can be supplied to the stapler.

– Staple Mode Disabling Conditions –

1. Under the following conditions, staple mode is disabled.

- If there is paper in a bin before the main switch is turned on.
- If the selected paper size does not match the stapling specifications.
- If the paper is fed from the by-pass feed table.
- If the stack or interrupt modes are selected.

2. Under the following conditions, staple mode is canceled if it had been selected.

- If paper is inserted into a bin by hand while the staple mode is selected.
- If only one sheet is delivered to the bin.
- If the number of sheets to be stapled exceeds the stapler capacity.

3.9 PAPER FEED AND MISFEED DETECTION TIMING

– **Proof Mode** – A4 sideways, 5 copies, 150 mm/s

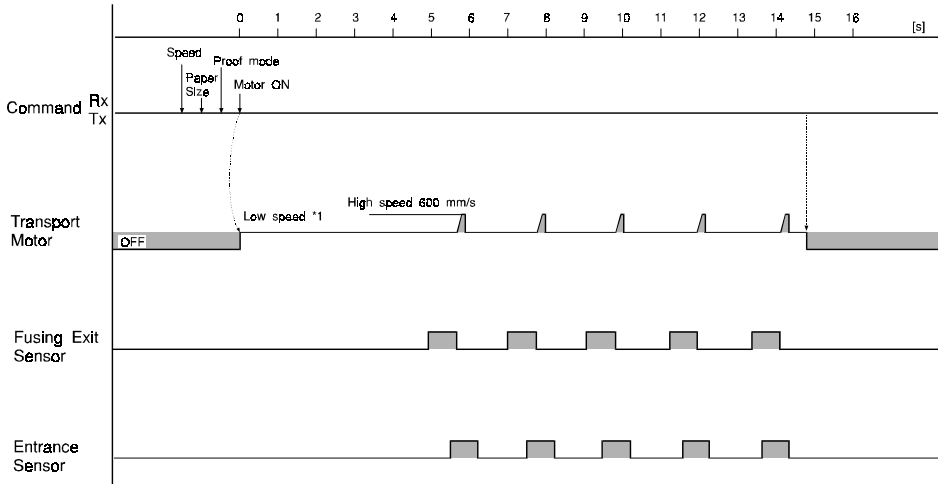

A658D512.wmf

*1: The value of the low speed depends on the copier.

– **Sorter Mode** – A4 sideways, two copies a of two-page original, 150 mm/s

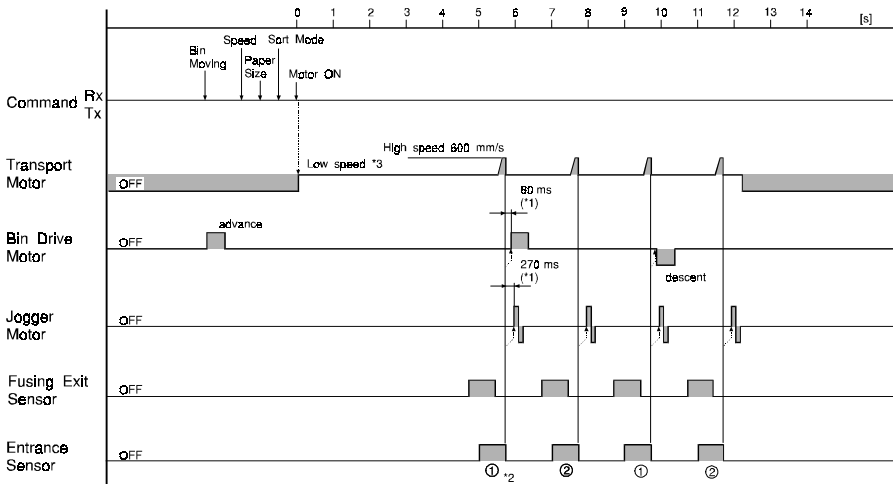

A658D513.wmf

*1: The start times of the bin drive and the jogger motors depend on the paper size as shown in the following table.

*2: Bin No.

Paper Size	Bin drive motor timing	Jogger motor timing	Paper Size	Bin drive motor timing	Jogger motor timing
A3/11"x17"	80 ms	270 ms	A4 lengthwise/ 8 1/2"x11"	254 ms	96 ms
B4	160 ms	190 ms	B5 sideways	160 ms	190 ms
A4 sideways/ 11"x8 1/2"	80 ms	270 ms	B5 lengthwise	310 ms	40 ms

– **Staple Mode** – A4 sideways, two copies of a two-page original, after sorting, 150 mm/s

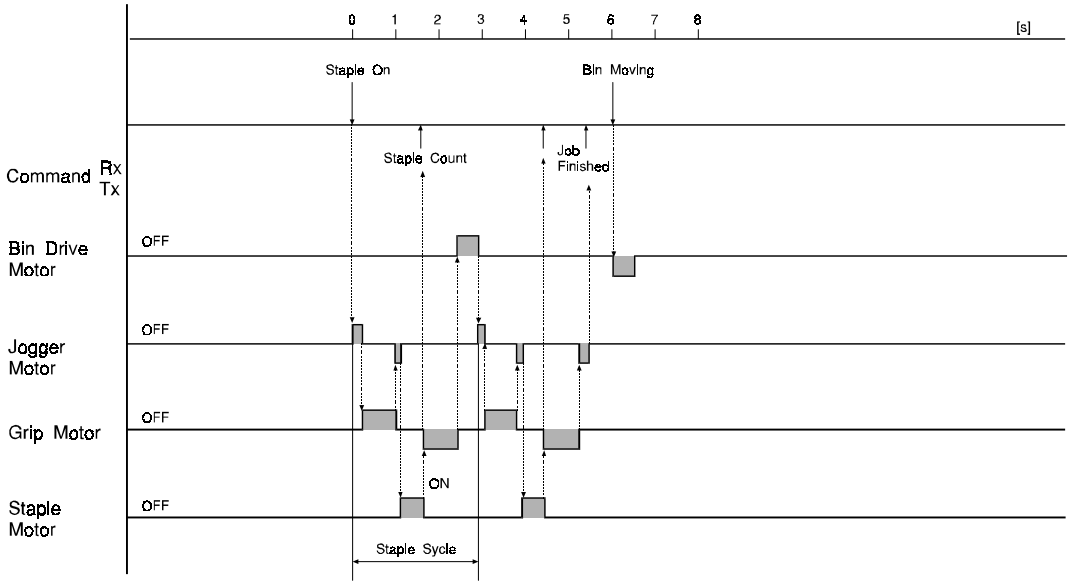

A658D514.wmf

3.10 JAM DETECTION

– Paper Jam – A4 sideways

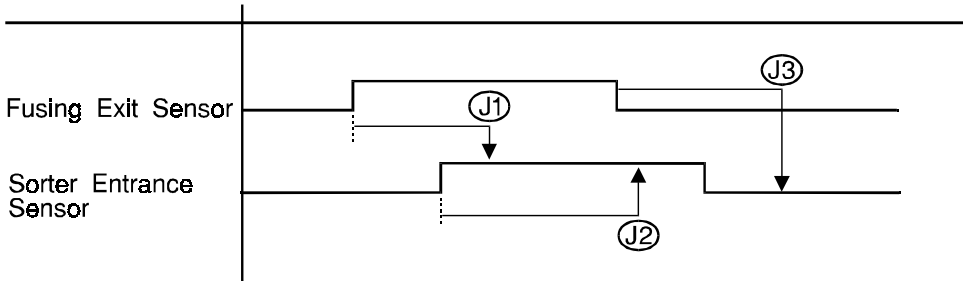

A658D515.wmf

- J1: The sorter entrance sensor does not turn on within 2 s after the fusing exit sensor has turned on.
- J2: The fusing exit sensor does not turn off within 11.4 s after the sorter entrance sensor has turned on.
- J3: The sorter entrance sensor does not turn off within 1 s after the fusing exit sensor has turned off.

– Staple Jam –

In the following conditions, a staple jam will occur and the sorter jam indicator on the operation panel will light.

1. If the stapler paper sensor is on when the main switch turns on or just as the stapler cover is closed.
2. If the stapler paper sensor stays on after the stapling job has been finished.

4. REPLACEMENT AND ADJUSTMENT

4.1 EXTERIOR COVER REMOVAL

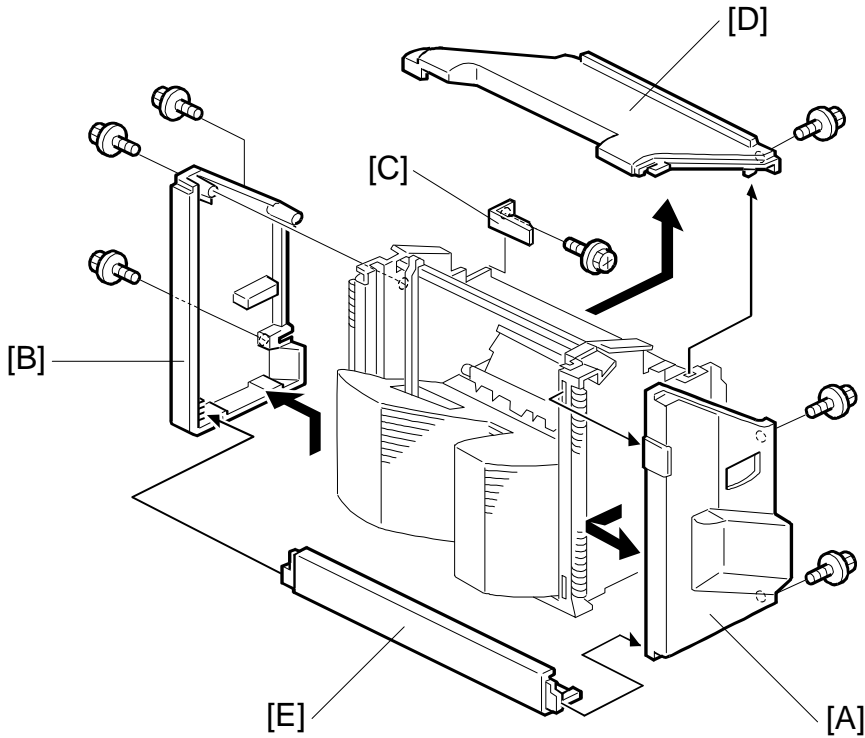

A658R506.wmf

4.1.1 Front Cover

1. Remove the front cover [A] (2 screws).

4.1.2 Rear Cover

1. Remove the rear cover [B] (3 screws).

4.1.3 Top Cover

1. Remove the rear cover [B].
2. Remove the top cover support bracket [C] (1 screw).
3. Remove the top cover [D] (1 screw).

4.1.4 Lower Cover

1. Remove the front cover [A] and the rear cover [B].
2. Remove the lower cover [E].

4.2 STAPLER UNIT REMOVAL

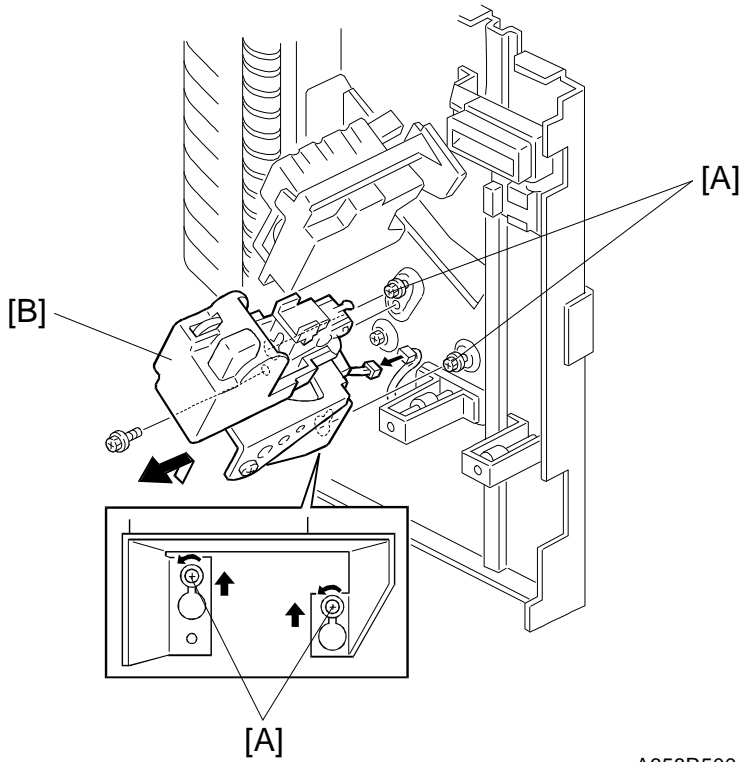

A658R500.wmf

1. Remove the front cover. (See Exterior Cover Removal.)
2. Loosen the screws [A].
3. Remove the stapler unit [B], as shown (1 screw and 1 connector).

4.3 GRIP ARM REPLACEMENT

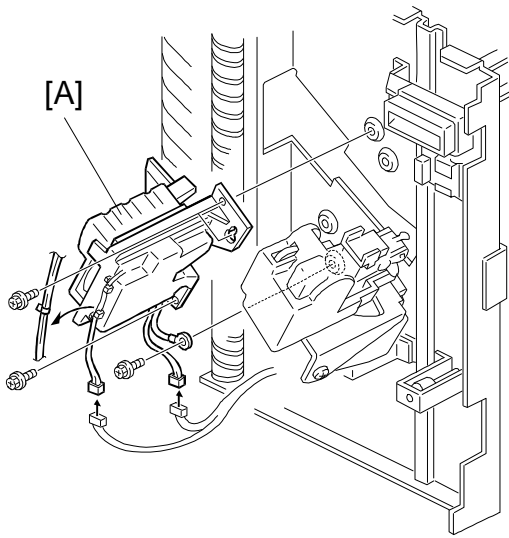

A658R501.wmf

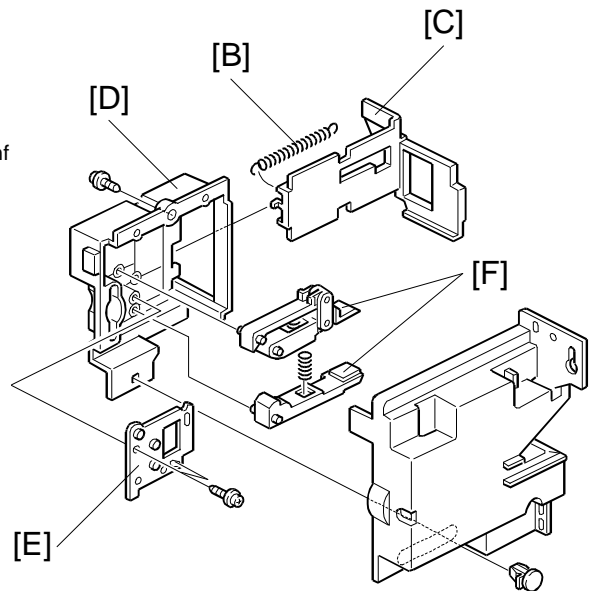

A658R502.wmf

1. Remove the front cover. (See Exterior Cover Removal.)
2. Remove the grip assembly [A] (4 screws, 2 connectors, and 1 grounding wire).
3. Remove the spring [B] and remove the slider [C].
4. Remove the grip arm unit [D] (1 screw and 1 clip).
5. Remove the grip arm plate [E] (2 screws).
6. Replace the grip arms [F].

4.4 BIN REMOVAL

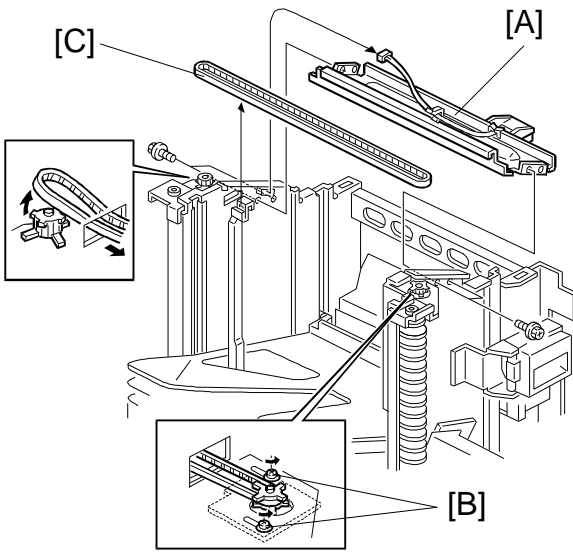

A658R503.wmf

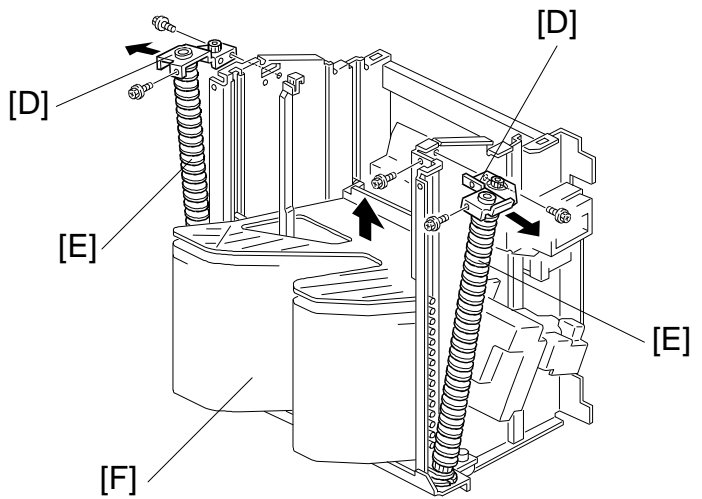

A658R504.wmf

1. Remove the front, rear, and top covers. (See Exterior Cover Removal.)
2. Remove the upper stay bracket [A] (4 screws and 1 connector).
3. Loosen the two screws [B], then remove the timing belt [C].
4. Remove the brackets [D] (3 springs each).
5. While moving the helical wheels [E] outward, remove the bins [F].

4.5 TRANSPORT MOTOR REMOVAL

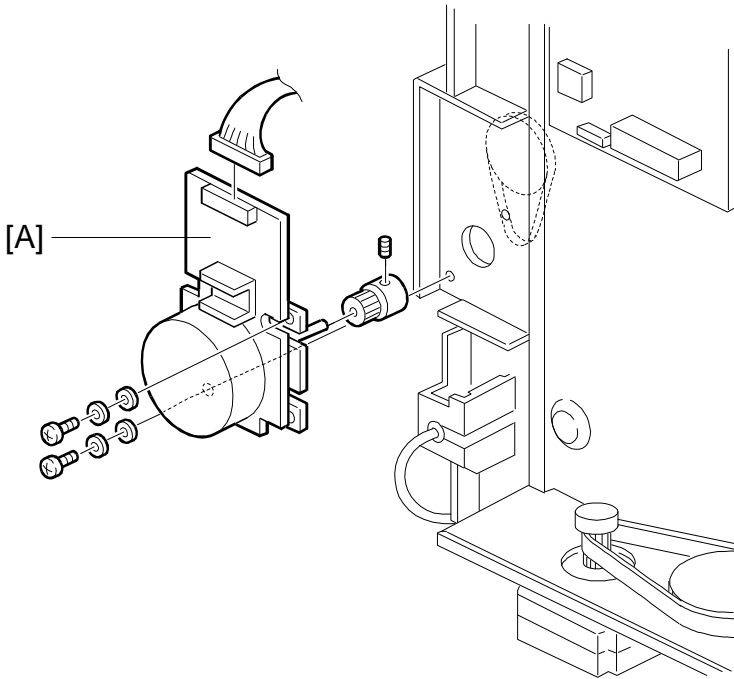

A658R505.wmf

1. Remove the sorter stapler (1 screw and 1 chain).
2. Remove the rear cover. (See Exterior Cover Removal.)
3. Remove the transport motor [A] (2 screws and 4 washers).

11.7 20-BIN SORTER STAPLER (A658) ACCESSORY CHECK

Check the accessories against the following list:

Description	Q'ty
1. Staple Position Decal	1
2. Chain	1
3. Cap Remover	1
4. Philips Pan Head Screw - M4 x 14.....	5
5. New Equipment Condition Report (Multi-language)	1
6. Installation Procedure (English).....	1
7. Stepped Screw	1

11.8 20-BIN SORTER STAPLER (A658) INSTALLATION PROCEDURE

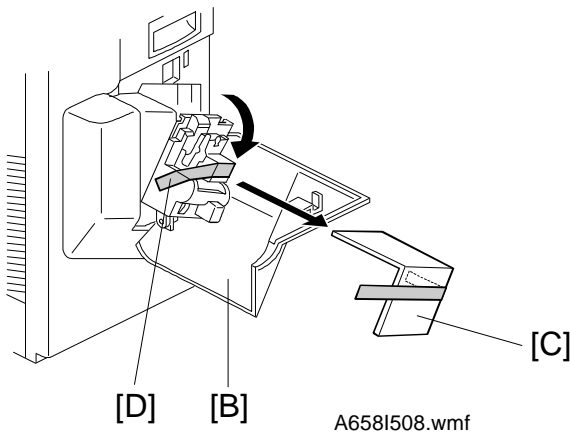
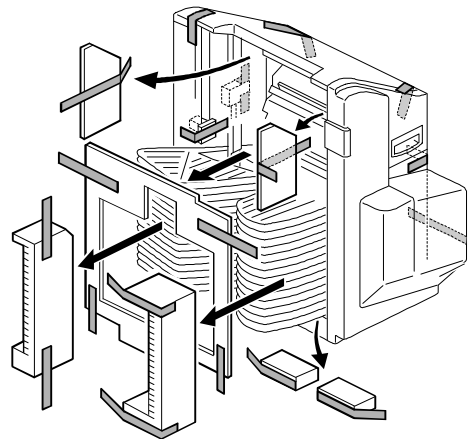
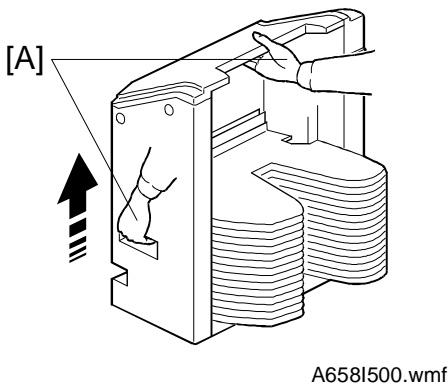

⚠ CAUTION

Unplug the copier power cord before starting the following procedure. When handling the sorter stapler, make sure to hold the parts shown [A]. Otherwise, the resulting damage may cause paper jams at the entrance.

- NOTE:**
- 1) Keep the shipping retainers after installing the machine. They will be reused if the machine will be transported to another location.
 - 2) Proper reinstallation of the shipping retainers is required in order to avoid any transport damage.
 - 3) A sorter adapter (A568) is required to install this sorter stapler in the A208/A210/A211 copiers. Before installing this sorter stapler, please install the sorter adapter.

1. Remove the strips of tape and the shipping retainers as shown.
2. Open the front door [B] and remove the cardboard [C] and the strip of tape [D] from the staple unit. Close the front door.

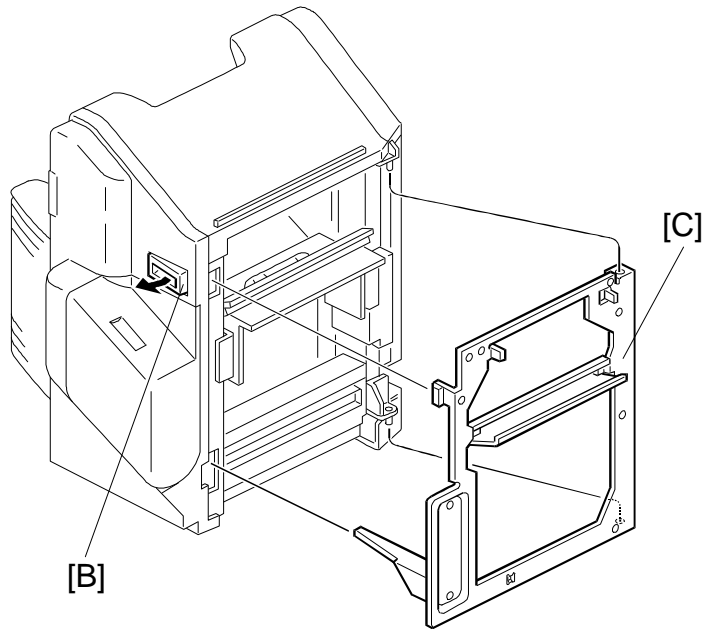
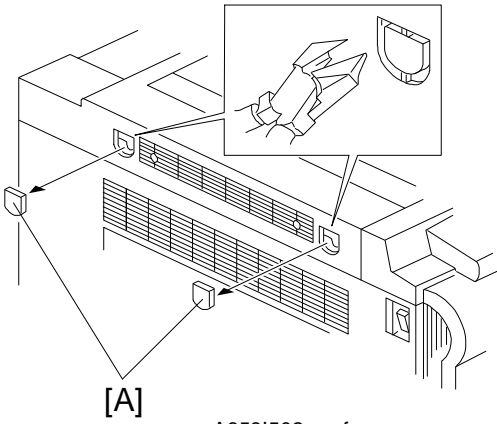

3. Remove the two plastic caps [A] from the copier left cover with nippers.
4. By releasing the open lever [B] of the sorter stapler, remove the sorter stapler mounting frame [C], as shown.

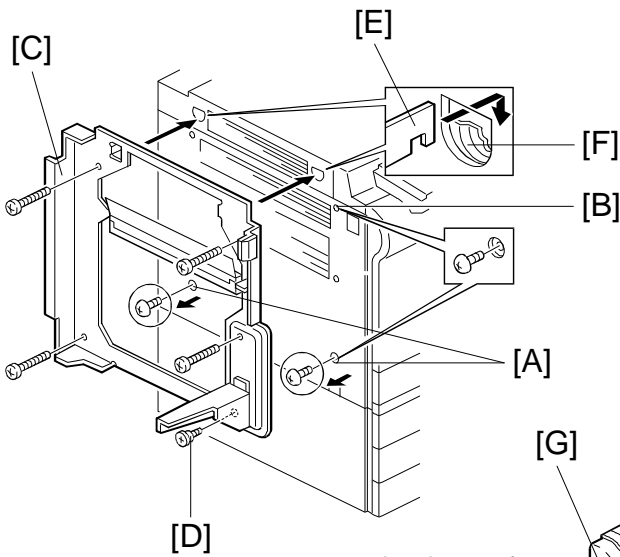

A658I504.wmf

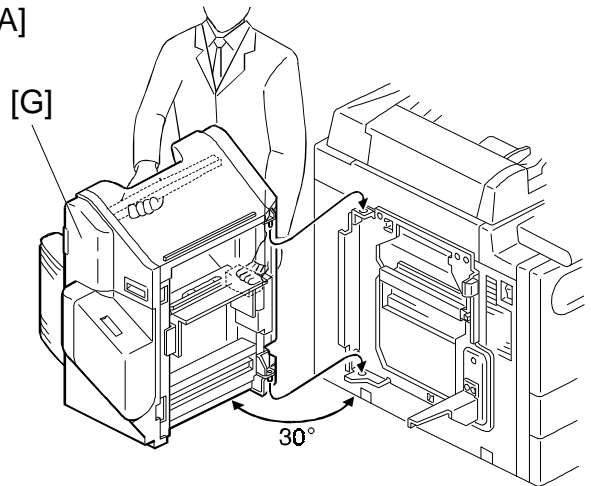

A658I505.wmf

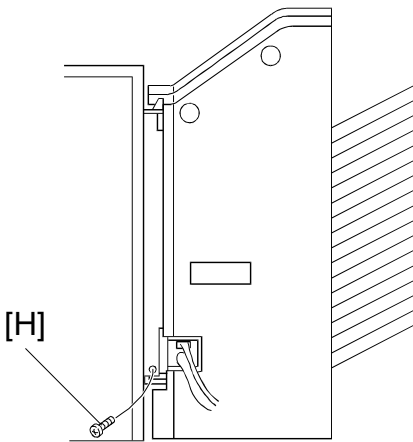

A658I506.wmf

5. Remove the M4 x 8 round head screws (2 screws [A] for the **A204/A206/A207 copiers**, 3 screws [A] and [B] for **A208/A210/A211 copiers**) from the left cover of the copier.

6. Mount the sorter stapler mounting frame [C] on the copier as shown (4 screws M4 x 14 and 1 stepped screw [D]).

NOTE: When hooking the sorter stapler mounting frame on the left side of the copier, make sure that the positioning hooks [E] on the frame are properly inserted in the positioning holes [F] in the copier.

7. Install the sorter stapler [G] on the frame (2 hinge pins at the rear) as shown.

8. Tighten the M4 x 14 screw [H].

NOTE: This screw prevents the sorter stapler from falling down.

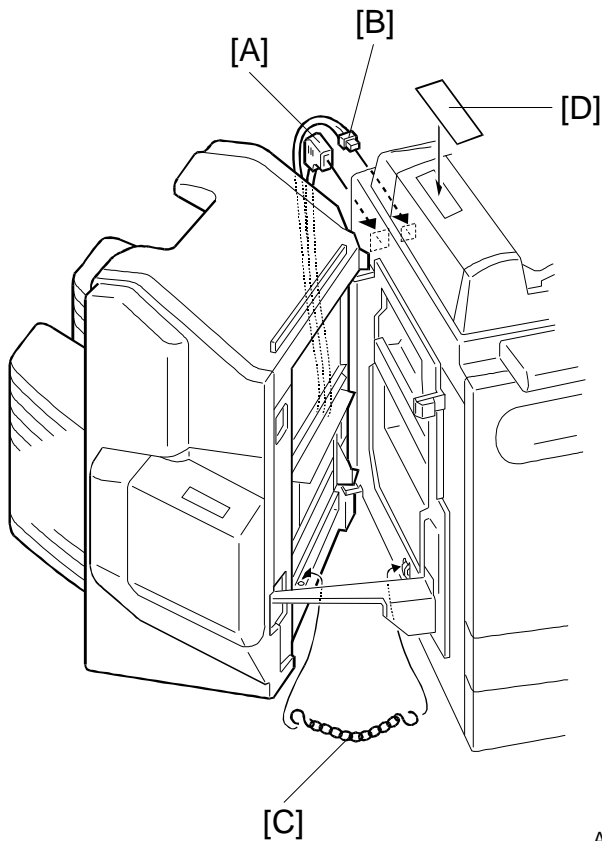

A6581507.wmf

9. Connect the cable [A] and the optic cable [B].
10. Install the chain [C] as shown.
11. Attach the staple position decal [D], as shown.
12. Plug in the copier.
13. Turn on the main switch of the copier and test the operation of the sorter stapler.

NOTE: The copier automatically recognizes that the sorter stapler has been installed.

20 BIN SORTER STAPLER (A658) ELECTRICAL COMPONENT LAYOUT

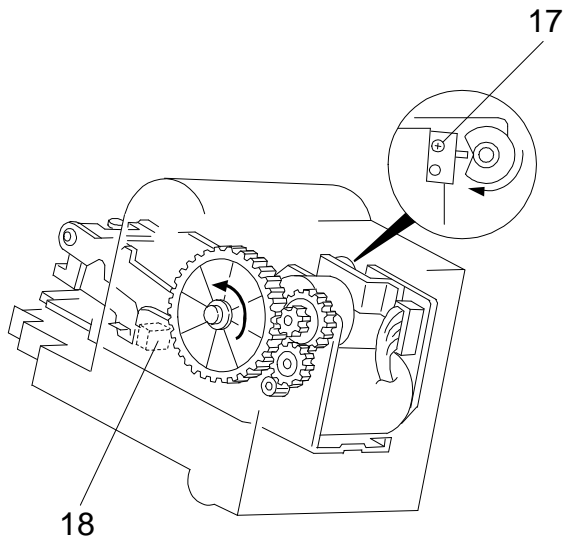
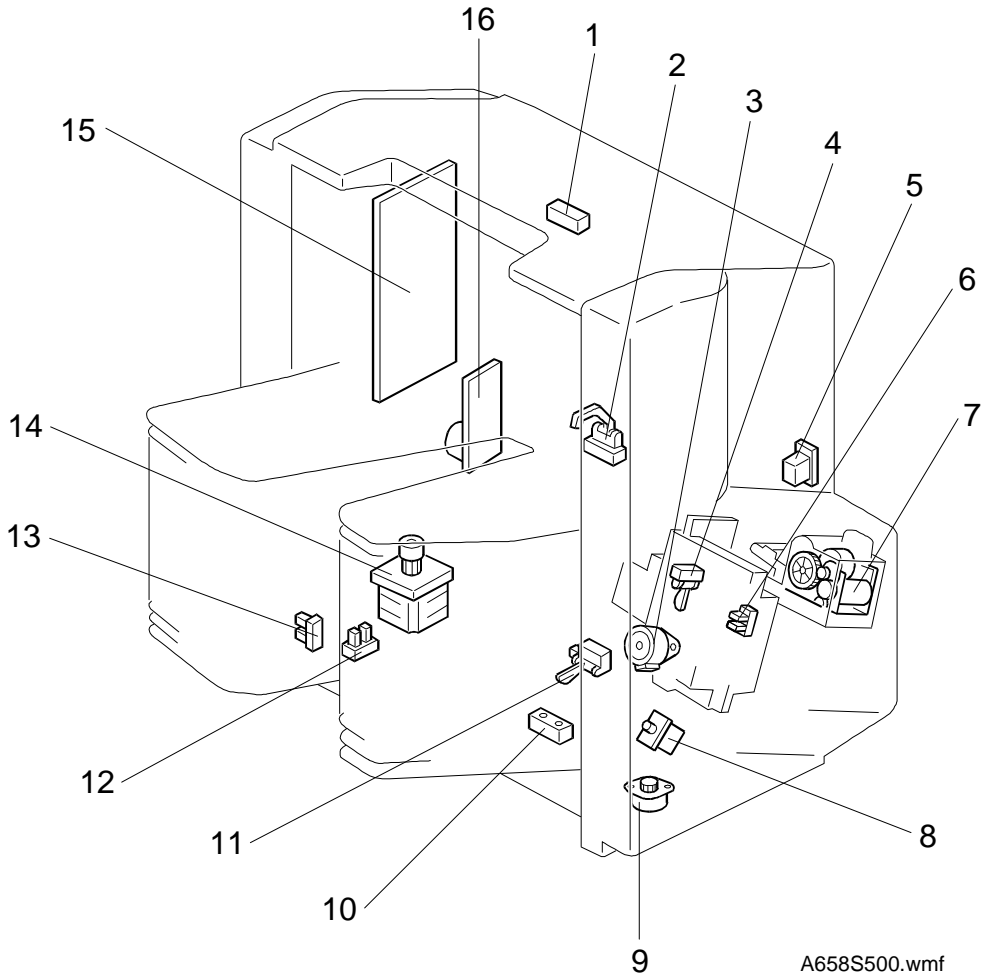

Description	Index No.	P to P Location
Bin Sensor (Photo tr.) (S1)	1	I16
Sorter Entrance Sensor (S4)	2	H16
Grip Motor (M5)	3	H2
Stapler Paper Sensor (S8)	4	C16
Door Safety Switch (SW1)	5	A5
Grip Home Position Sensor (S2)	6	D16
Stapler Motor (M4)	7	D1
Stapler Switch (SW2)	8	F5
Jogger Motor (M2)	9	G2
Bin Sensor (LED) (S7)	10	L16
Bin Home Position Sensor (S3)	11	K16
Wheel Sensor (S6)	12	B16
Jogger Home Position Sensor (S5)	13	A16
Bin Drive Motor (M3)	14	J2
Main Board (PCB1)	15	F8
Main Drive Motor (M1)	16	F17
Staple Home Position Sensor (S10)	17	E1
Staple End Sensor (S9)	18	E1